

8 7 6 5 4 3 2 1

D
C
B
A

D
C
B
A

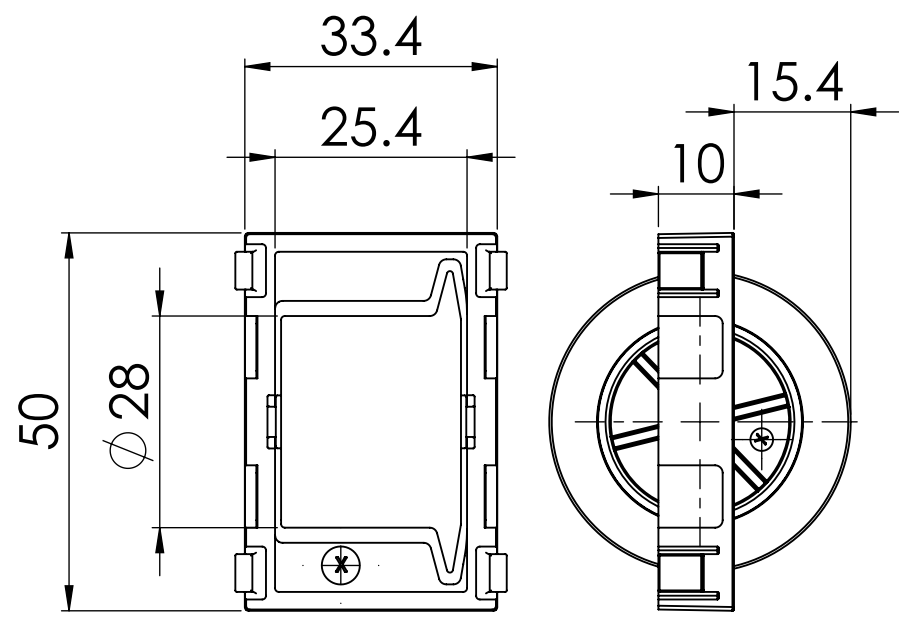
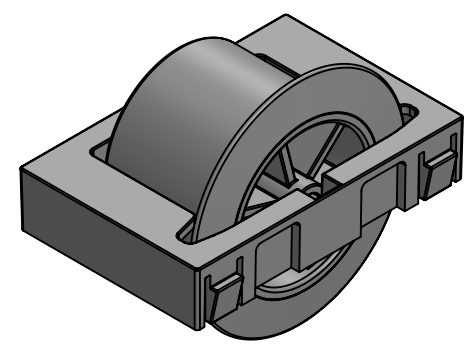

NOTE :-
ALL UNMENTIONED FILLETS ARE 0.2 MM

		UNLESS OTHERWISE SPECIFIED:		NAME	DATE		
		DIMENSIONS ARE IN MILLIMETERS		DRAWN		TITLE:	
		TOLERANCES:		CHECKED			
		FRACTIONAL ±		ENG APPR.			
		ANGULAR: MACH ± BEND ±		MFG APPR.			
		TWO PLACE DECIMAL ±		Q.A.		SIZE	
		THREE PLACE DECIMAL ±		PROJECTION:		DWG. NO.	
		INTERPRET GEOMETRIC TOLERANCING PER: ISO 2768 MEDIUM				801202	
		MATERIAL				REV	
NEXT ASSY		USED ON				SCALE: 1:1	
APPLICATION		DO NOT SCALE DRAWING		DEBURR AND BREAK SHARP EDGES		WEIGHT:	
						SHEET 1 OF 1	

8 7 6 5 4 3 2 1