

8 7 6 5 4 3 2 1

D  
C  
B  
A

D  
C  
B  
A

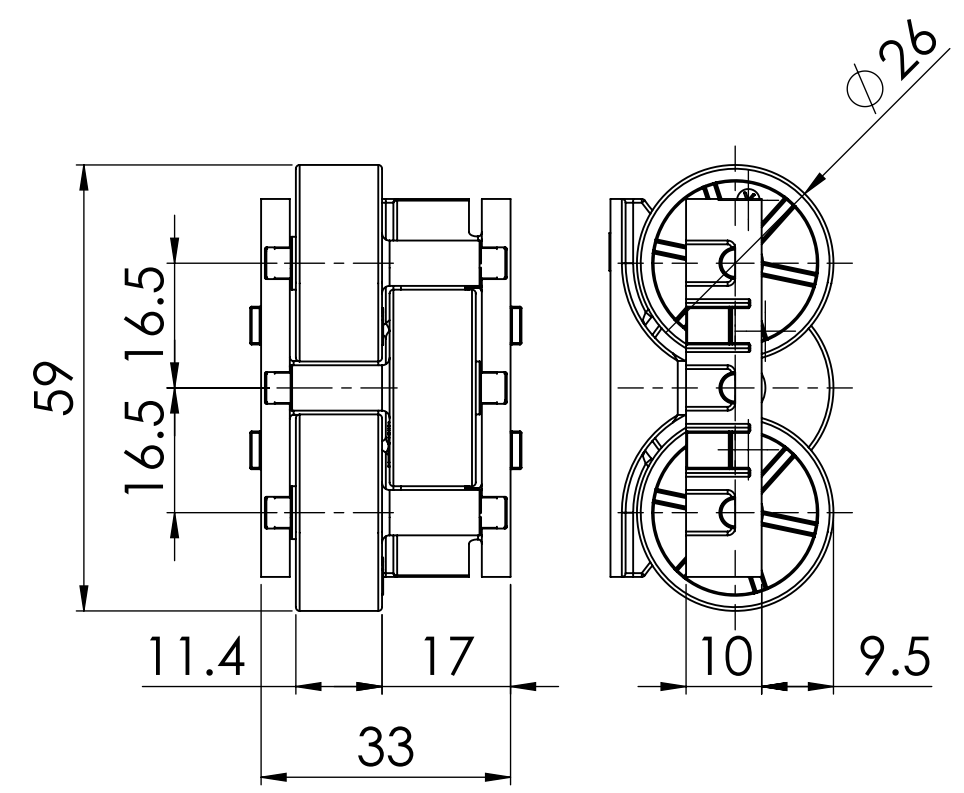
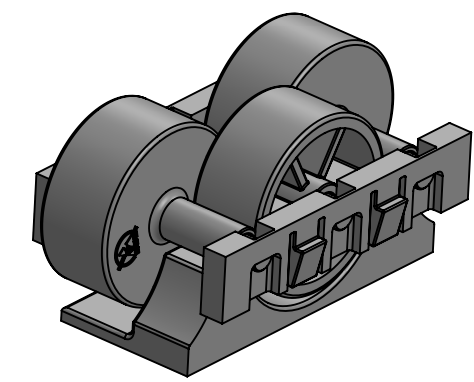

NOTE :-  
ALL UNMENTIONED FILLETS ARE 0.2 MM

		UNLESS OTHERWISE SPECIFIED:		NAME	DATE		
		DIMENSIONS ARE IN MILLIMETERS		DRAWN		TITLE:	
		TOLERANCES:		CHECKED			
		FRACTIONAL $\pm$		ENG APPR.			
		ANGULAR: MACH $\pm$ BEND $\pm$		MFG APPR.			
		TWO PLACE DECIMAL $\pm$		Q.A.		SIZE	
		THREE PLACE DECIMAL $\pm$		PROJECTION:		DWG. NO.	
		INTERPRET GEOMETRIC TOLERANCING PER: ISO 2768 MEDIUM				801103	
		MATERIAL				REV	
		FINISH				SCALE: 1:1	
NEXT ASSY	USED ON	DO NOT SCALE DRAWING		DEBURR AND BREAK SHARP EDGES		WEIGHT:	
APPLICATION						SHEET 1 OF 1	

8 7 6 5 4 3 2 1