

8 7 6 5 4 3 2 1

D
C
B
A

D
C
B
A

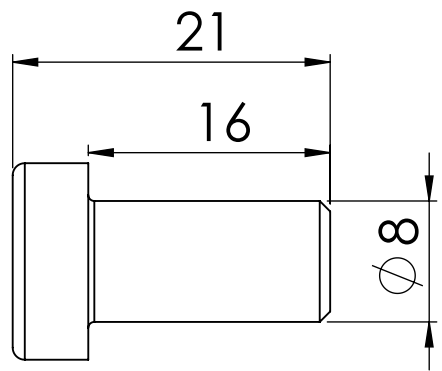
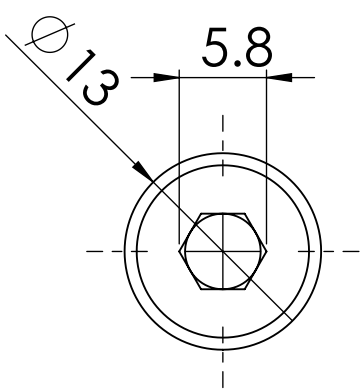
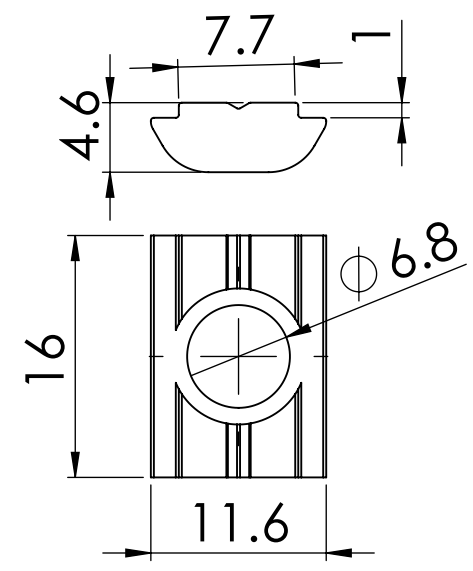
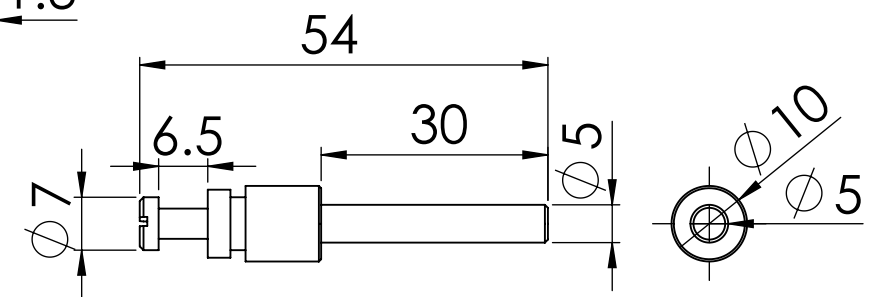
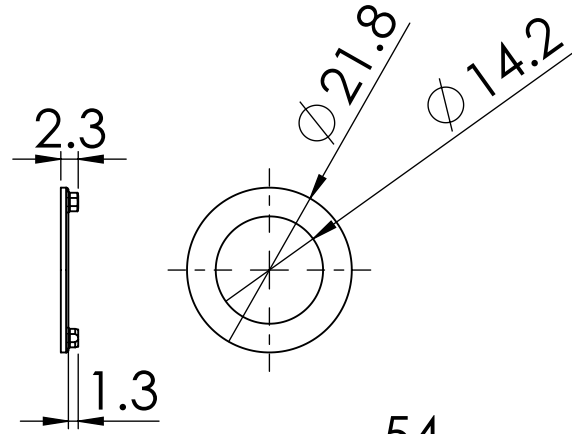
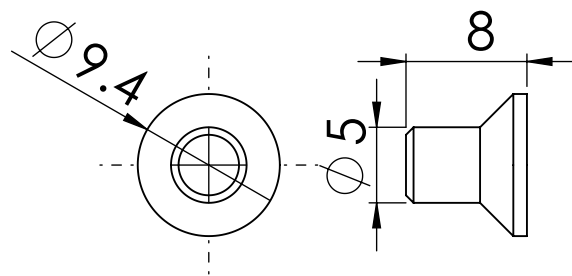
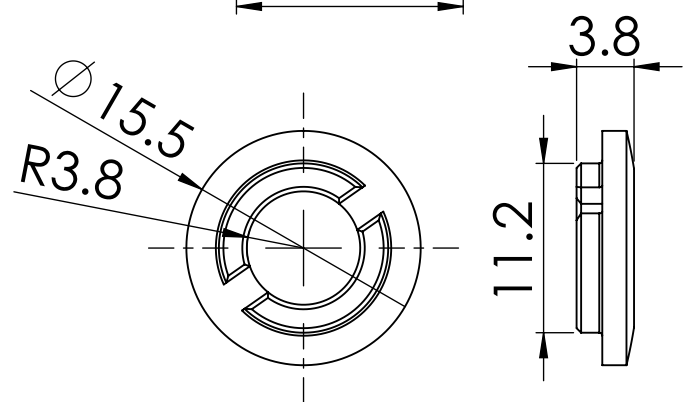
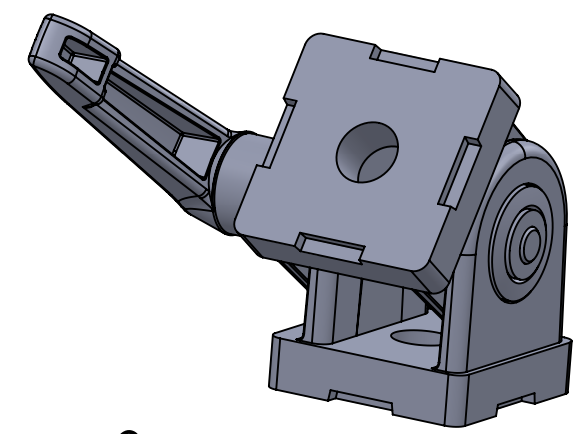
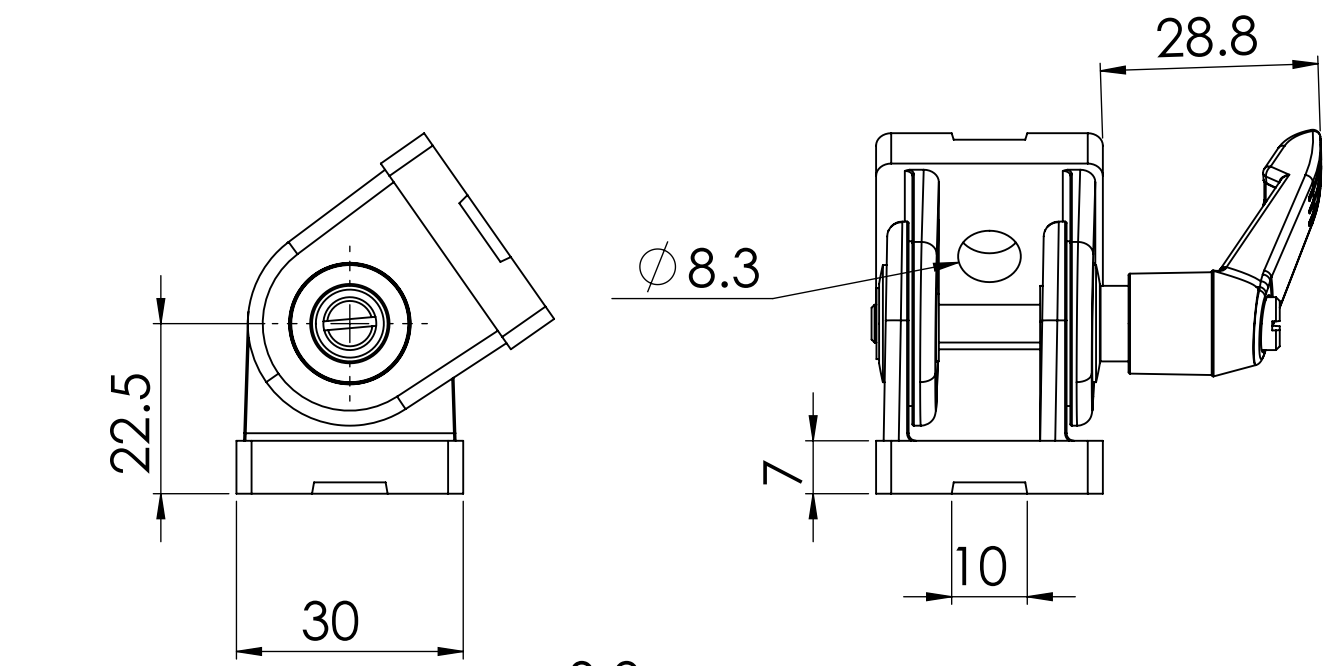

NOTE :-
ALL UNMENTIONED FILLETS ARE 0.2 MM

		UNLESS OTHERWISE SPECIFIED:		NAME	DATE
		DIMENSIONS ARE IN MILLIMETERS		DRAWN	
		TOLERANCES:		CHECKED	
		FRACTIONAL ±		ENG APPR.	
		ANGULAR: MACH ± BEND ±		MFG APPR.	
		TWO PLACE DECIMAL ±		Q.A.	
		THREE PLACE DECIMAL ±		PROJECTION:	
		INTERPRET GEOMETRIC TOLERANCING PER: ISO 2768 MEDIUM			
		MATERIAL			
		FINISH			
NEXT ASSY	USED ON				
APPLICATION		DO NOT SCALE DRAWING		DEBURR AND BREAK SHARP EDGES	
				SCALE: 1:1	WEIGHT:
				SHEET 1 OF 1	
			TITLE:		
			SIZE B		DWG. NO. 484500600
					REV

8 7 6 5 4 3 2 1