

8 7 6 5 4 3 2 1

D  
C  
B  
A

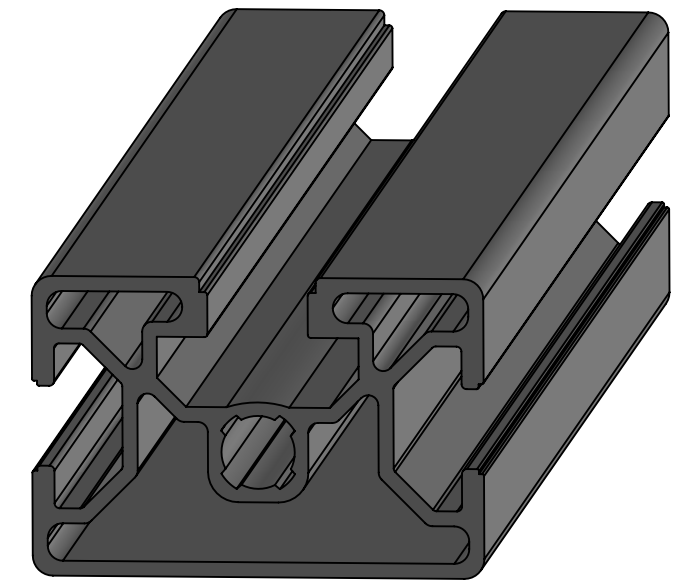
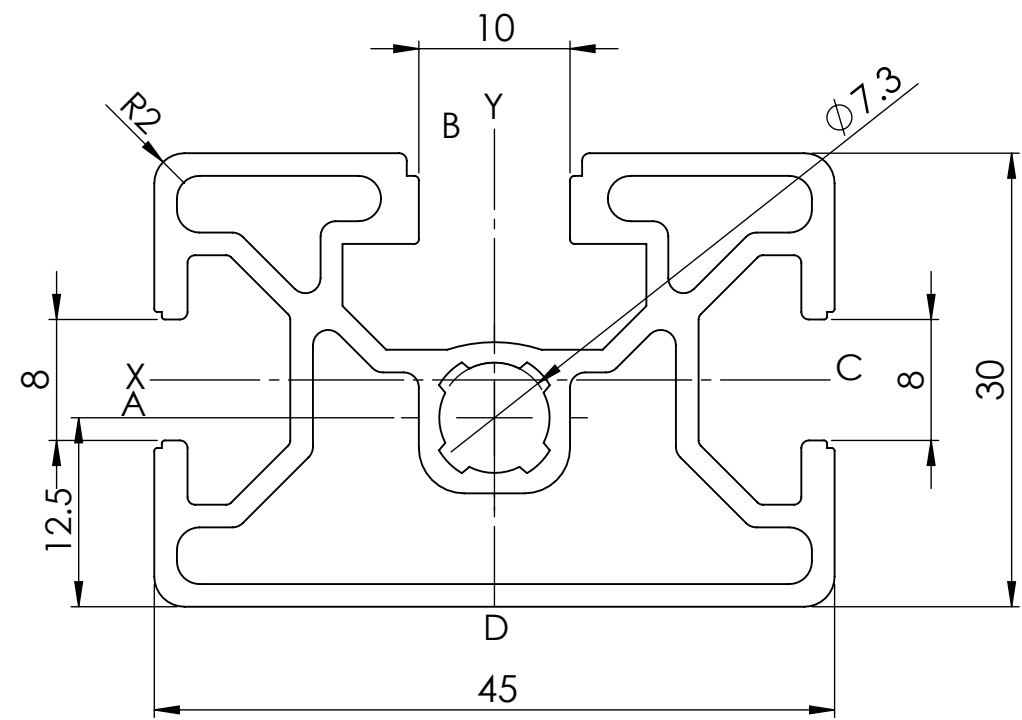

D  
C  
B  
A

NOTE :-  
ALL UNMENTIONED FILLETS ARE 0.2 MM

		UNLESS OTHERWISE SPECIFIED:		NAME	DATE	
		DIMENSIONS ARE IN MILLIMETERS	DRAWN			TITLE:
		TOLERANCES:	CHECKED			
		FRACTIONAL ±	ENG APPR.			
		ANGULAR: MACH ± BEND ±	MFG APPR.			
		TWO PLACE DECIMAL ±				
		THREE PLACE DECIMAL ±				
		INTERPRET GEOMETRIC TOLERANCING PER: ISO 2768 MEDIUM	Q.A.			
		MATERIAL	PROJECTION:			SIZE DWG. NO. REV
		FINISH	THIRD ANGLE PROJECTION			<b>B</b> 481992430
NEXT ASSY	USED ON		DEBURR AND BREAK SHARP EDGES			SCALE: 1:2 WEIGHT: SHEET 1 OF 1
APPLICATION		DO NOT SCALE DRAWING				

8 7 6 5 4 3 2 1