

4 3 2 1

B

B

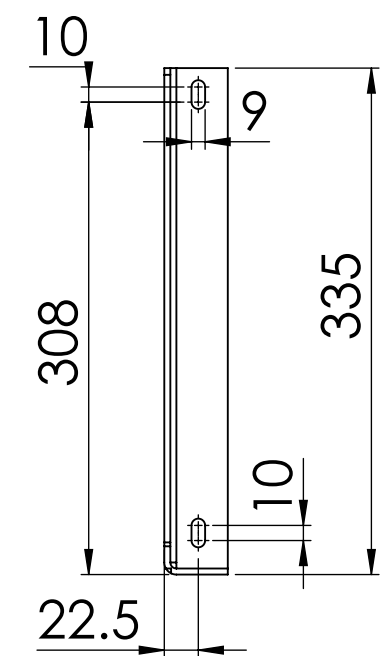
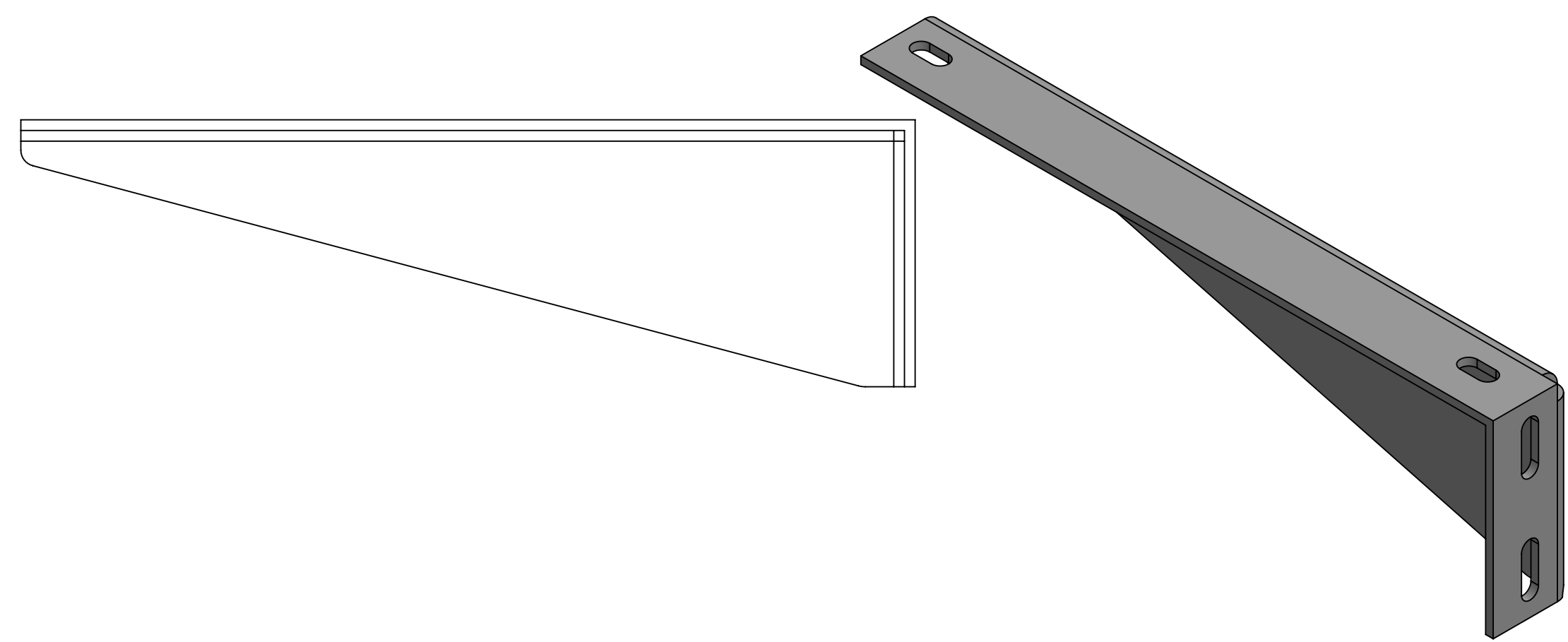
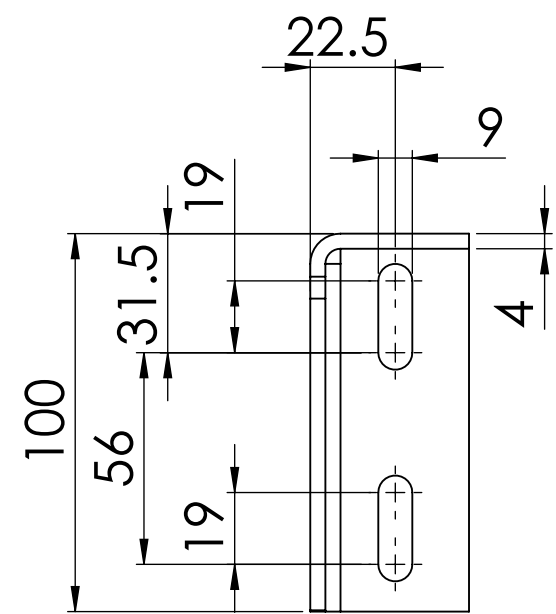

A

A

Note:-
*ALL UNMENTIONED FILLETS ARE 0.2MM

		UNLESS OTHERWISE SPECIFIED:		NAME	DATE		
		DIMENSIONS ARE IN MILLIMETERS		DRAWN		TITLE:	
		TOLERANCES:		CHECKED			
		FRACTIONAL ±		ENG APPR.			
		ANGULAR: MACH ± BEND ±		MFG APPR.			
		TWO PLACE DECIMAL ±		Q.A.		Projection:-	
		THREE PLACE DECIMAL ±		THIRD ANGLE PROJECTION		SIZE	DWG. NO.
		INTERPRET GEOMETRIC TOLERANCING PER:ISO 2768 MEDIUM				B	412536121
		MATERIAL				REV	
		FINISH					
NEXT ASSY	USED ON						
APPLICATION		DO NOT SCALE DRAWING		DEBURR AND BREAK SHARP EDGES		SCALE: 1:2	WEIGHT:
						SHEET 1 OF 1	

4 3 2 1