

4 3 2 1

B

A

B

A

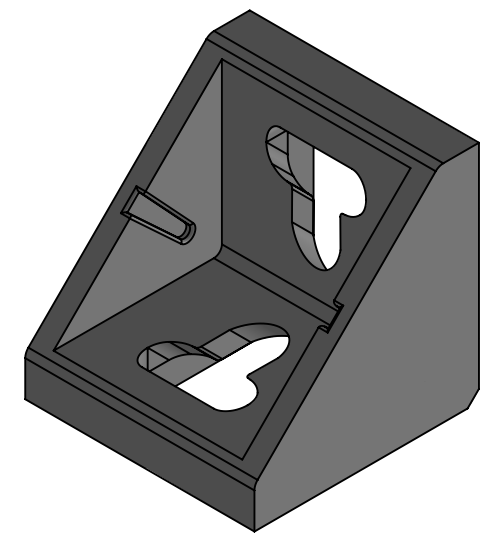
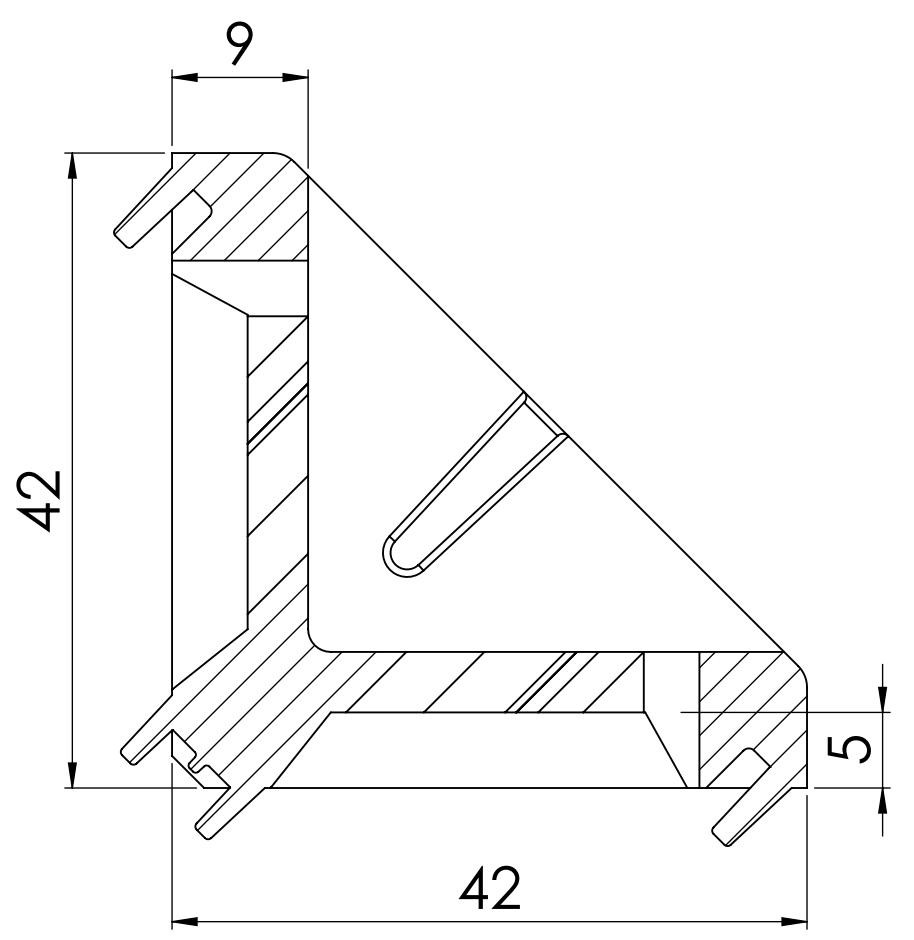
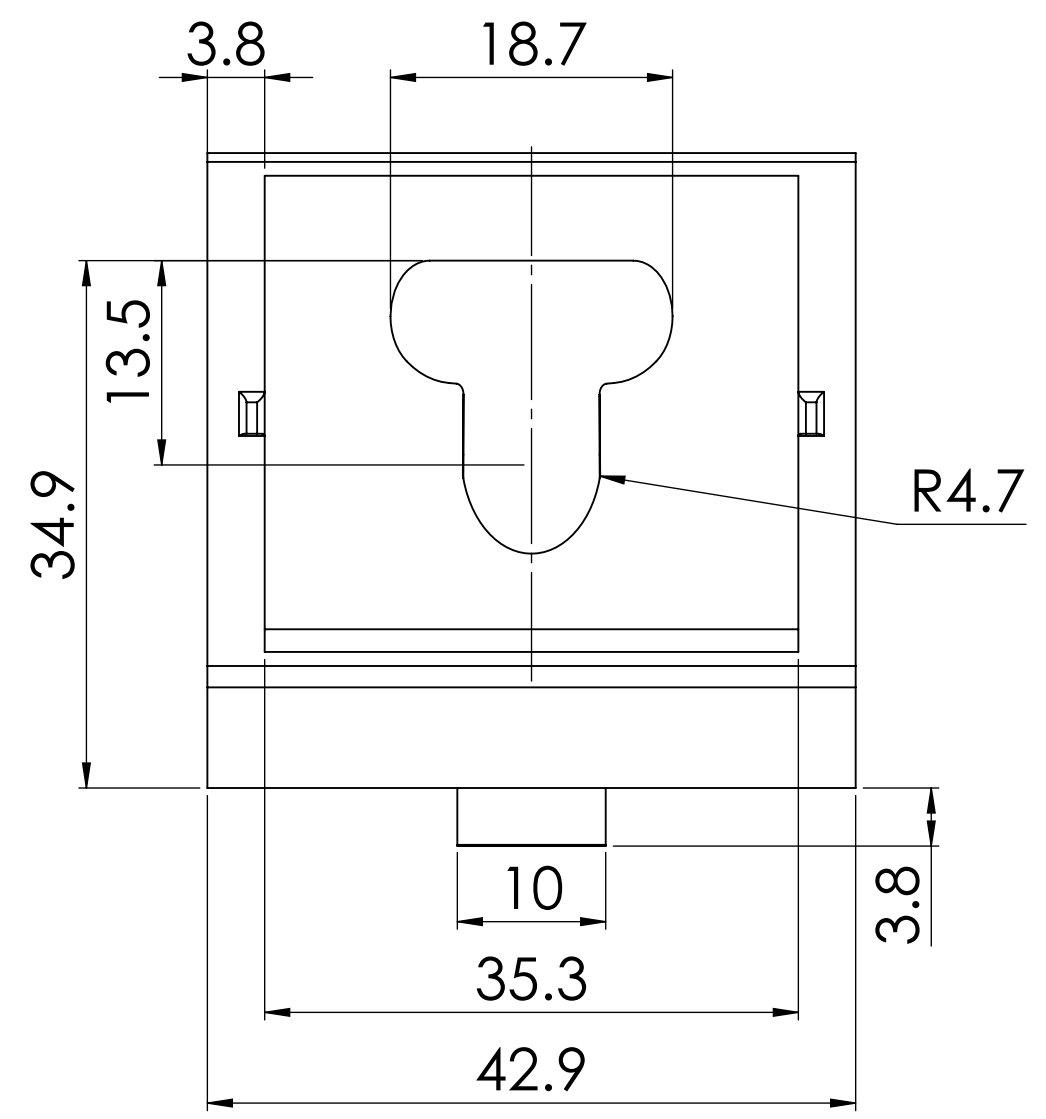

Note:-  
\*ALL UNMENTIONED FILLETS ARE 0.2MM

		UNLESS OTHERWISE SPECIFIED:		NAME	DATE		
		DIMENSIONS ARE IN MILLIMETERS		DRAWN			
		TOLERANCES:		CHECKED		TITLE:	
		FRACTIONAL ±		ENG APPR.			
		ANGULAR: MACH ± BEND ±		MFG APPR.			
		TWO PLACE DECIMAL ±		Q.A.			
		THREE PLACE DECIMAL ±		Projection:-			
		INTERPRET GEOMETRIC TOLERANCING PER:ISO 2768 MEDIUM		THIRD ANGLE PROJECTION		SIZE	DWG. NO.
		MATERIAL				<b>B</b>	412348526
		FINISH				SCALE: 1:1	WEIGHT:
NEXT ASSY	USED ON	DO NOT SCALE DRAWING		DEBURR AND BREAK SHARP EDGES		SHEET 1 OF 1	REV

4 3 2 1