

4

3

2

1

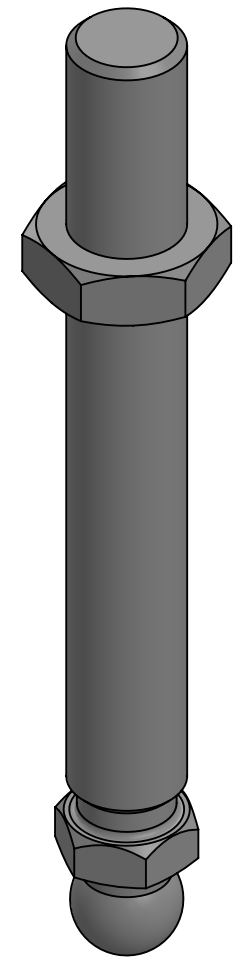
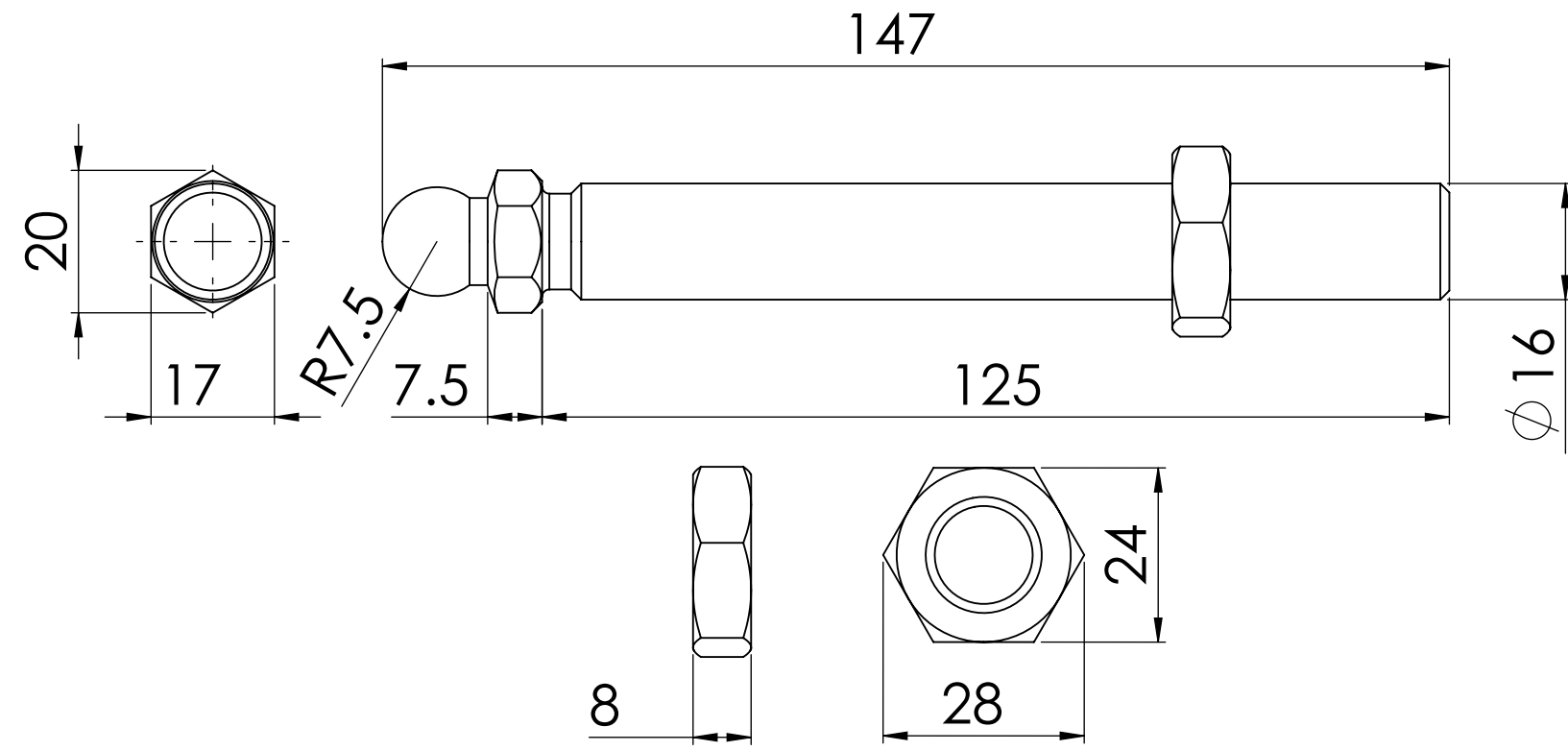

B

B

A

A

Note:-
*ALL UNMENTIONED FILLETS ARE 0.2MM

		UNLESS OTHERWISE SPECIFIED:	NAME	DATE		
		DIMENSIONS ARE IN MILLIMETERS	DRAWN			
		TOLERANCES:	CHECKED		TITLE:	
		FRACTIONAL \pm	ENG APPR.			
		ANGULAR: MACH \pm BEND \pm	MFG APPR.			
		TWO PLACE DECIMAL \pm	Q.A.			
		THREE PLACE DECIMAL \pm	Projection:-			
		INTERPRET GEOMETRIC TOLERANCING PER:ISO 2768 MEDIUM	THIRD ANGLE PROJECTION			SIZE
		MATERIAL				DWG. NO.
		FINISH				REV
NEXT ASSY	USED ON					B
APPLICATION		DO NOT SCALE DRAWING	DEBURR AND BREAK SHARP EDGES			403537229
			SCALE: 1:2	WEIGHT:	SHEET 1 OF 1	

4

3

2

1