

SECTION A-A
SCALE 2 : 1

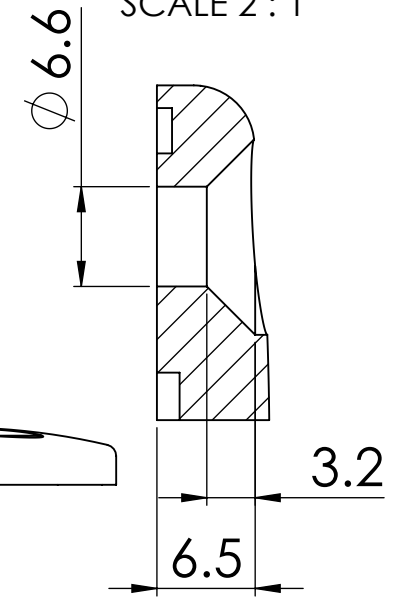

NOTE :-
ALL UNMENTIONED FILLETS ARE 0.2 MM

		UNLESS OTHERWISE SPECIFIED:		NAME	DATE			
		DIMENSIONS ARE IN MILLIMETERS		DRAWN		TITLE:		
		TOLERANCES:		CHECKED				
		FRACTIONAL ±		ENG APPR.				
		ANGULAR: MACH ± BEND ±		MFG APPR.				
		TWO PLACE DECIMAL ±		Q.A.		SIZE	DWG. NO.	REV
		THREE PLACE DECIMAL ±		PROJECTION:		B	402600003	
		INTERPRET GEOMETRIC TOLERANCING PER: ISO 2768 MEDIUM		THIRD ANGLE PROJECTION		SCALE: 1:1		WEIGHT:
		MATERIAL		DEBURR AND BREAK SHARP EDGES		SHEET 1 OF 1		
NEXT ASSY	USED ON	FINISH		DO NOT SCALE DRAWING				
APPLICATION								