

8 7 6 5 4 3 2 1

D
C
B
A

D
C
B
A

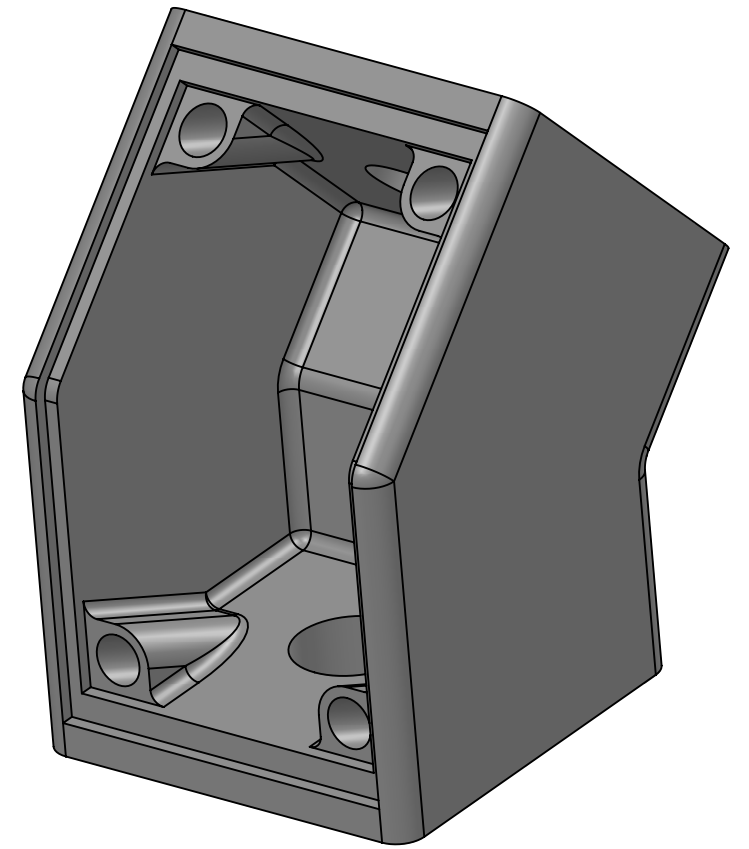
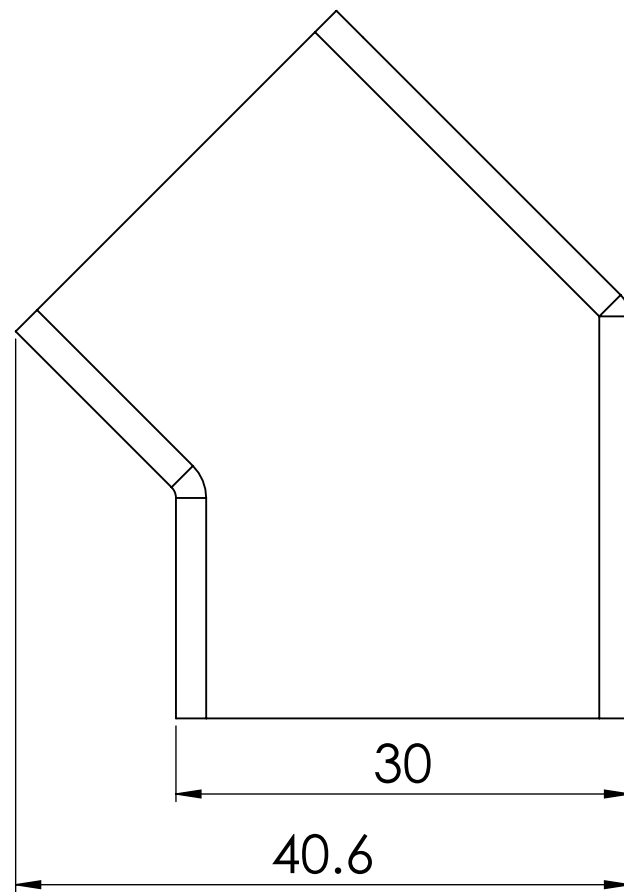
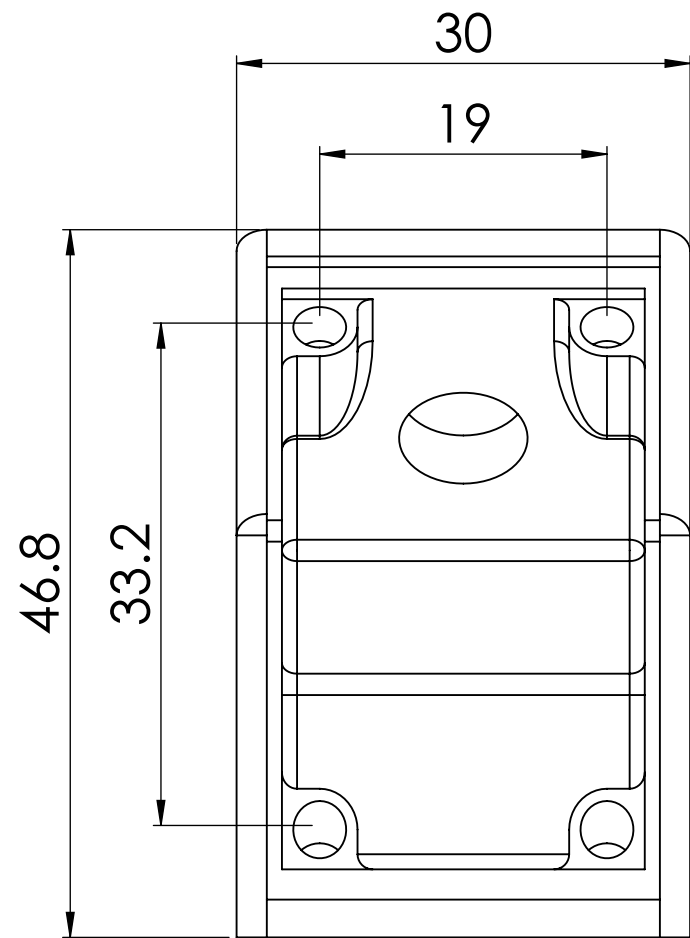

NOTE :-
ALL UNMENTIONED FILLETS ARE 0.2 MM

		UNLESS OTHERWISE SPECIFIED:		NAME	DATE		
		DIMENSIONS ARE IN MILLIMETERS		DRAWN		TITLE:	
		TOLERANCES:		CHECKED			
		FRACTIONAL ±		ENG APPR.			
		ANGULAR: MACH ± BEND ±		MFG APPR.			
		TWO PLACE DECIMAL ±		Q.A.		SIZE	DWG. NO.
		THREE PLACE DECIMAL ±		PROJECTION:		B	402518426
		INTERPRET GEOMETRIC TOLERANCING PER: ISO 2768 MEDIUM				REV	
		MATERIAL				SCALE: 2:1	WEIGHT:
		FINISH				SHEET 1 OF 1	
NEXT ASSY	USED ON	DO NOT SCALE DRAWING		DEBURR AND BREAK SHARP EDGES			
APPLICATION							

8 7 6 5 4 3 2 1