

8 7 6 5 4 3 2 1

D  
C  
B  
A

D  
C  
B  
A

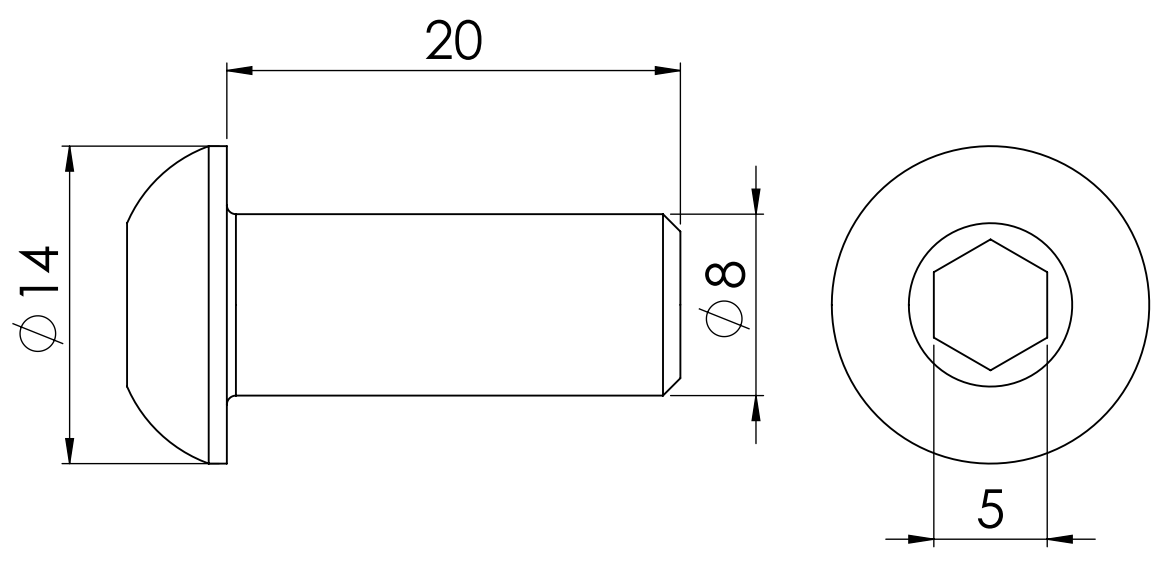
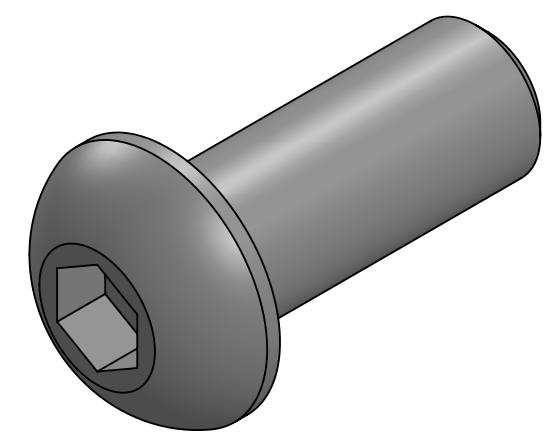

NOTE :-  
ALL UNMENTIONED FILLETS ARE 0.2 MM

		UNLESS OTHERWISE SPECIFIED:		NAME	DATE			
		DIMENSIONS ARE IN MILLIMETERS		DRAWN		TITLE:		
		TOLERANCES:		CHECKED				
		FRACTIONAL ±		ENG APPR.				
		ANGULAR: MACH ± BEND ±		MFG APPR.				
		TWO PLACE DECIMAL ±		Q.A.				
		THREE PLACE DECIMAL ±		PROJECTION:				
		INTERPRET GEOMETRIC TOLERANCING PER: ISO 2768 MEDIUM				SIZE	DWG. NO.	REV
		MATERIAL				<b>B</b>	402150018	
NEXT ASSY	USED ON	FINISH				SCALE: 2:1	WEIGHT:	SHEET 1 OF 1
APPLICATION		DO NOT SCALE DRAWING		DEBURR AND BREAK SHARP EDGES				

8 7 6 5 4 3 2 1