

4

3

2

1

B

B

A

A

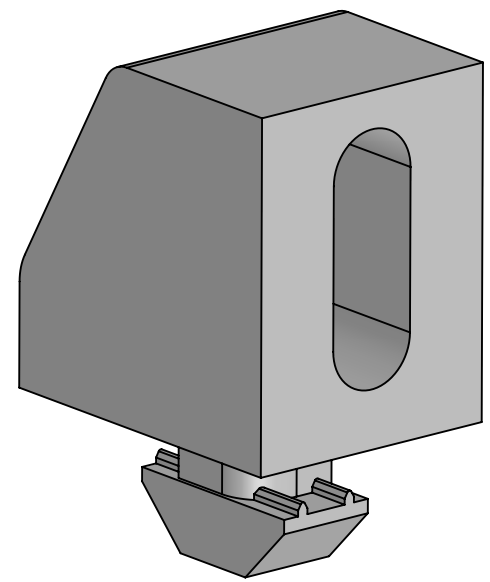
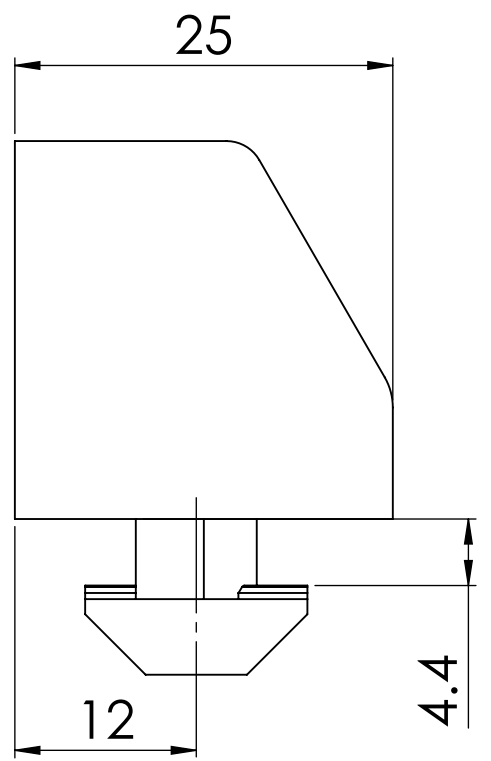
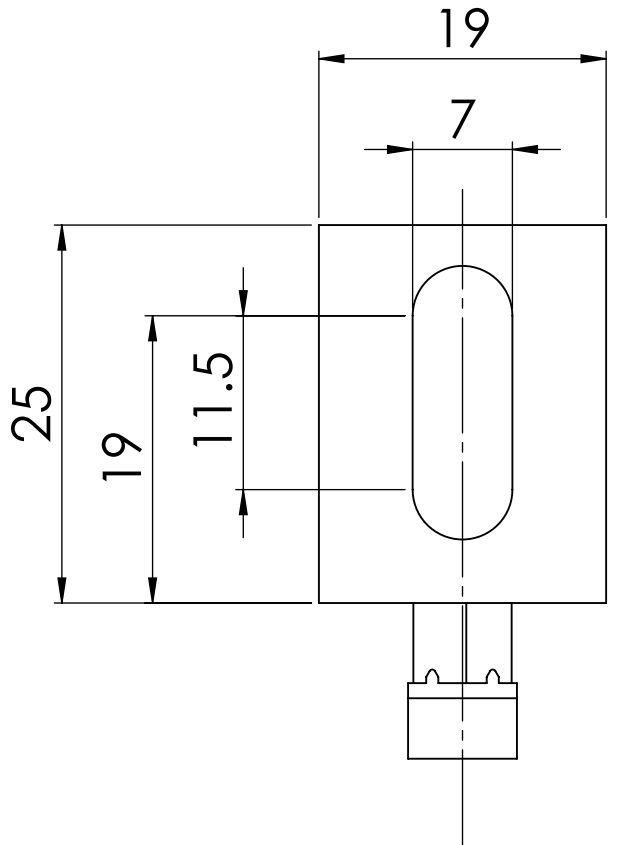

Note:-  
\*ALL UNMENTIONED FILLETS ARE 0.2MM

		UNLESS OTHERWISE SPECIFIED:	NAME	DATE		
		DIMENSIONS ARE IN MILLIMETERS	DRAWN			
		TOLERANCES:	CHECKED		TITLE:	
		FRACTIONAL ±	ENG APPR.			
		ANGULAR: MACH ± BEND ±	MFG APPR.			
		TWO PLACE DECIMAL ±	Q.A.			
		THREE PLACE DECIMAL ±	Projection:-			
		INTERPRET GEOMETRIC TOLERANCING PER:ISO 2768 MEDIUM	<b>THIRD ANGLE PROJECTION</b>	SIZE	DWG. NO.	REV
		MATERIAL		<b>B</b>	<b>285615005</b>	
NEXT ASSY	USED ON	FINISH				
APPLICATION		DO NOT SCALE DRAWING	<b>DEBURR AND BREAK SHARP EDGES</b>	SCALE: 2:1	WEIGHT:	SHEET 1 OF 1

4

3

2

1