

8 7 6 5 4 3 2 1

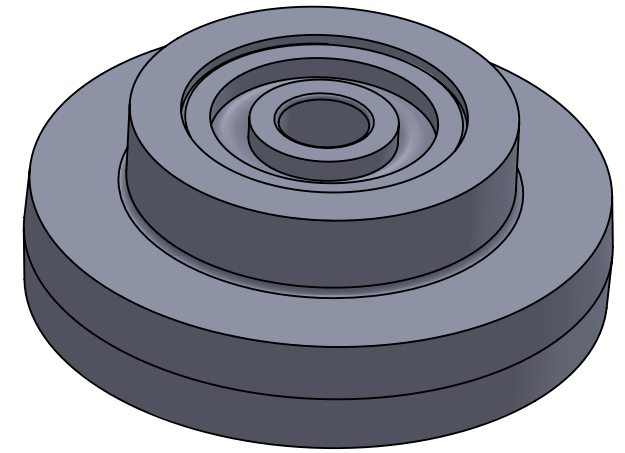
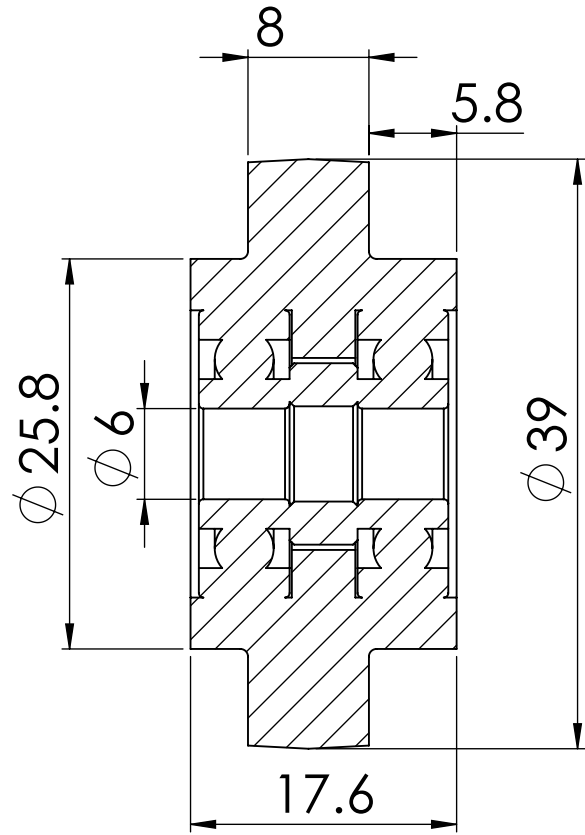
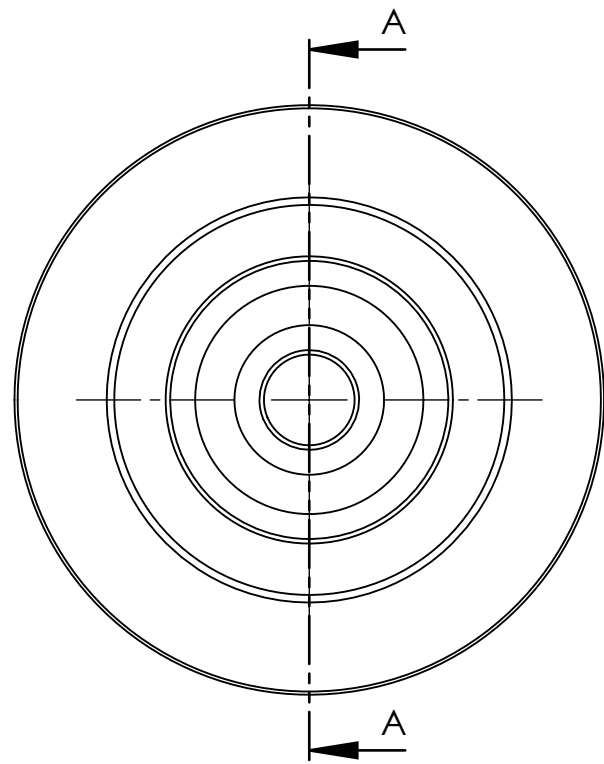

SECTION A-A
SCALE 2 : 1

NOTE :-
ALL UNMENTIONED FILLETS ARE 0.2 MM

		UNLESS OTHERWISE SPECIFIED:		NAME	DATE		
		DIMENSIONS ARE IN MILLIMETERS		DRAWN		TITLE:	
		TOLERANCES:		CHECKED			
		FRACTIONAL \pm		ENG APPR.			
		ANGULAR: MACH \pm BEND \pm		MFG APPR.			
		TWO PLACE DECIMAL \pm		Q.A.		SIZE DWG. NO. REV	
		THREE PLACE DECIMAL \pm		PROJECTION:			
		INTERPRET GEOMETRIC TOLERANCING PER: ISO 2768 MEDIUM				B 283218003	
		MATERIAL				SCALE: 1:1 WEIGHT: SHEET 1 OF 1	
NEXT ASSY	USED ON	FINISH		DEBURR AND BREAK SHARP EDGES			
APPLICATION		DO NOT SCALE DRAWING					

8 7 6 5 4 3 2 1