

4

3

2

1

B

B

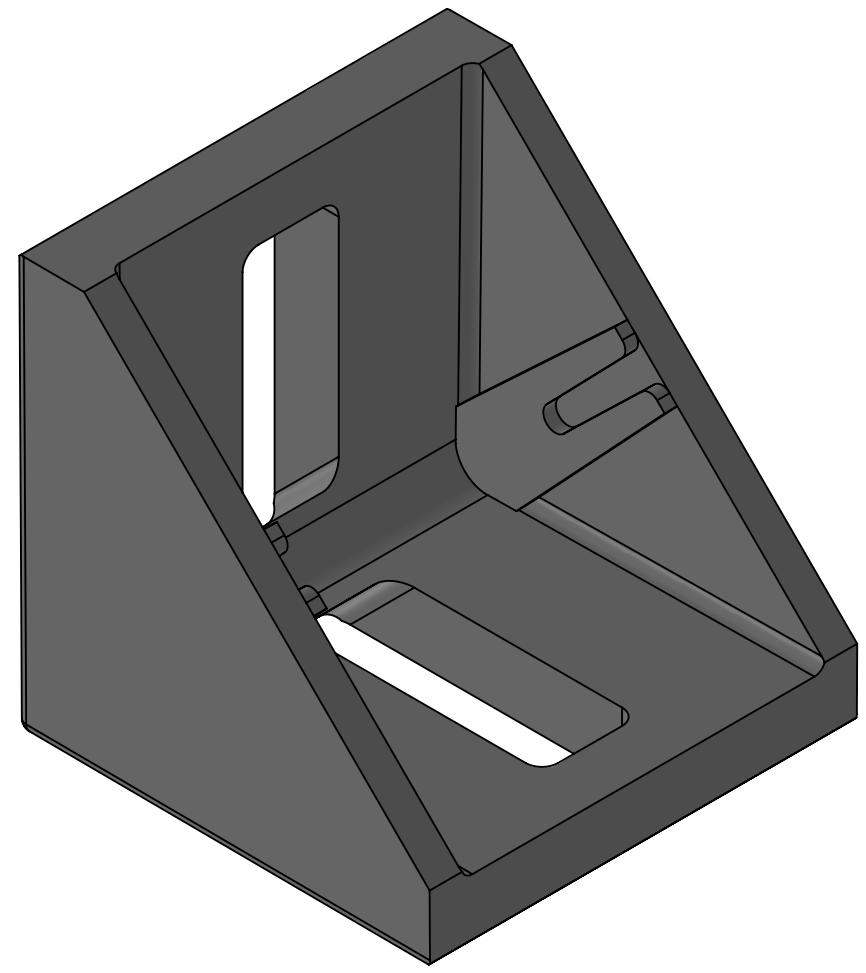
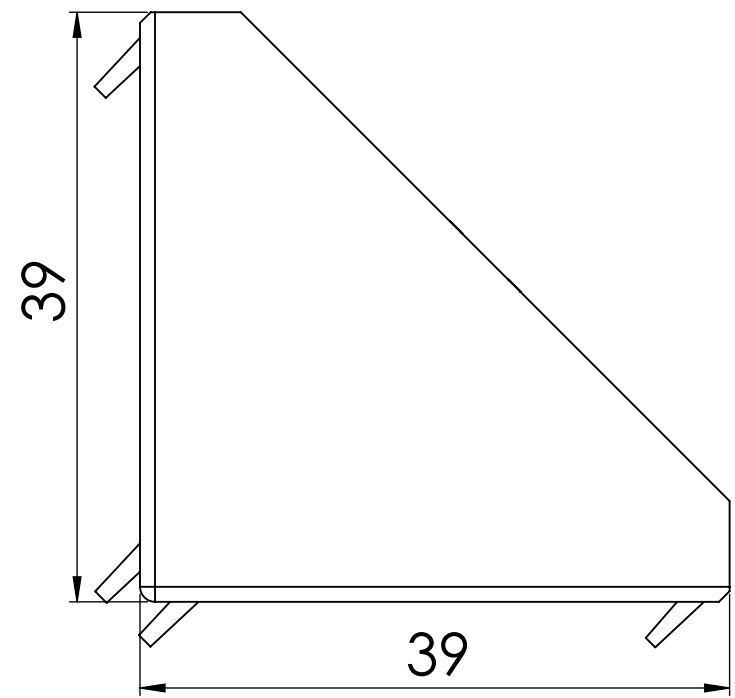
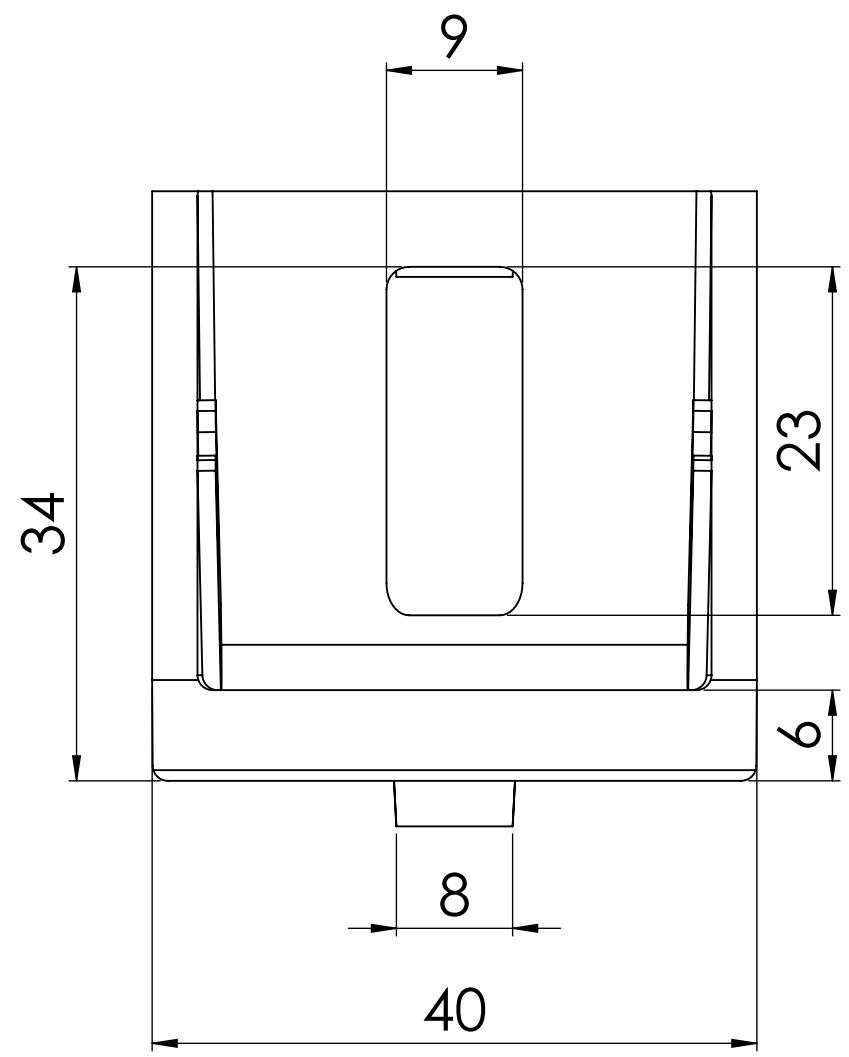

A

A

Note:-
*ALL UNMENTIONED FILLETS ARE 0.2MM

		UNLESS OTHERWISE SPECIFIED:		NAME	DATE		
		DIMENSIONS ARE IN MILLIMETERS		DRAWN		TITLE:	
		TOLERANCES:		CHECKED			
		FRACTIONAL ±		ENG APPR.			
		ANGULAR: MACH ± BEND ±		MFG APPR.			
		TWO PLACE DECIMAL ±		Q.A.			
		THREE PLACE DECIMAL ±		Projection:-			
		INTERPRET GEOMETRIC TOLERANCING PER:ISO 2768 MEDIUM		THIRD ANGLE PROJECTION		SIZE	DWG. NO.
		MATERIAL				B	282300252
		FINISH				REV	
NEXT ASSY	USED ON			DEBURR AND BREAK SHARP EDGES		SCALE: 2:1	WEIGHT:
APPLICATION		DO NOT SCALE DRAWING				SHEET 1 OF 1	

4

3

2

1