

8 7 6 5 4 3 2 1

D  
C  
B  
A

D  
C  
B  
A

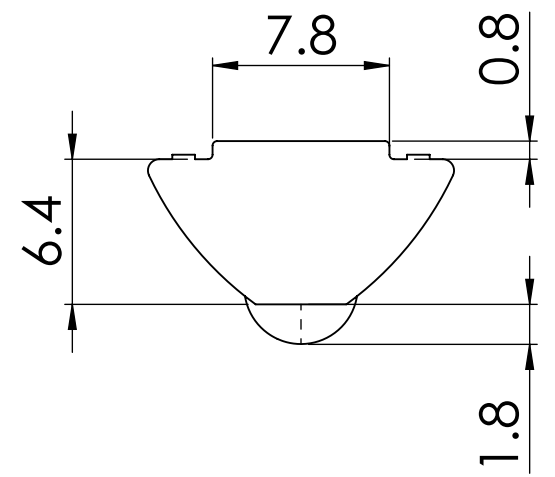
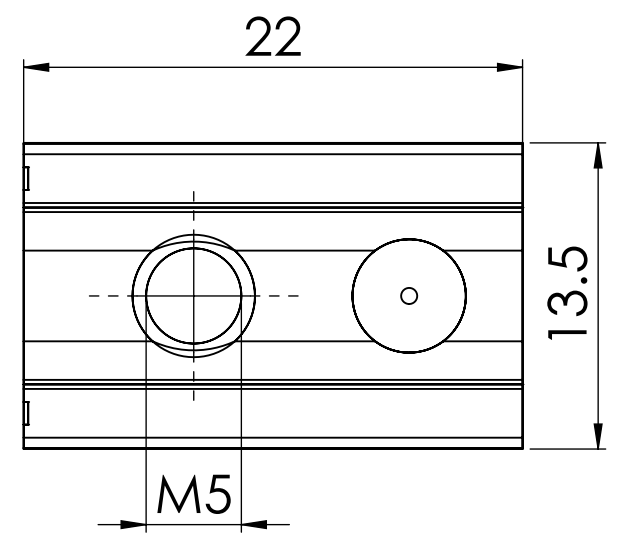
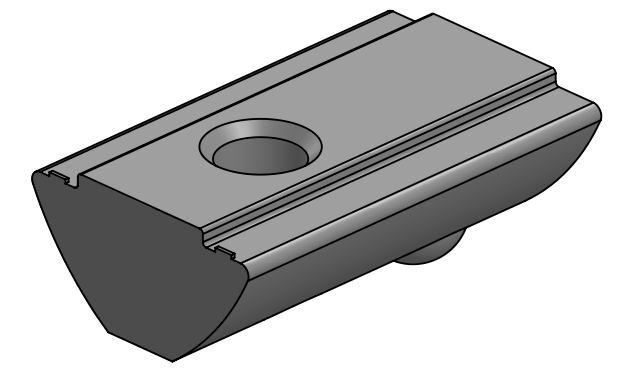

NOTE :-  
ALL UNMENTIONED FILLETS ARE 0.2 MM

|             |         |  |  |                              |      |                                 |  |
|-------------|---------|--|--|------------------------------|------|---------------------------------|--|
|             |         | UNLESS OTHERWISE SPECIFIED:                          |  | NAME                         | DATE |                                 |  |
|             |         | DIMENSIONS ARE IN MILLIMETERS                        |  | DRAWN                        |      | TITLE:                          |  |
|             |         | TOLERANCES:  |  | CHECKED                      |      |                                 |  |
|             |         | FRACTIONAL ±   |  | ENG APPR.                    |      |                                 |  |
|             |         | ANGULAR: MACH ± BEND ±                               |  | MFG APPR.                    |      |                                 |  |
|             |         | TWO PLACE DECIMAL ±                                  |  | Q.A.                         |      | SIZE DWG. NO. REV               |  |
|             |         | THREE PLACE DECIMAL ±                                |  | PROJECTION:                  |      | B 282200120                     |  |
|             |         | INTERPRET GEOMETRIC TOLERANCING PER: ISO 2768 MEDIUM |  | THIRD ANGLE PROJECTION       |      | SCALE: 2:1 WEIGHT: SHEET 1 OF 1 |  |
|             |         | MATERIAL   |  | DEBURR AND BREAK SHARP EDGES |      |                                 |  |
| NEXT ASSY   | USED ON | FINISH   |  |                              |      |                                 |  |
| APPLICATION |         | DO NOT SCALE DRAWING                                 |  |                              |      |                                 |  |

8 7 6 5 4 3 2 1