

4

3

2

1

B

B

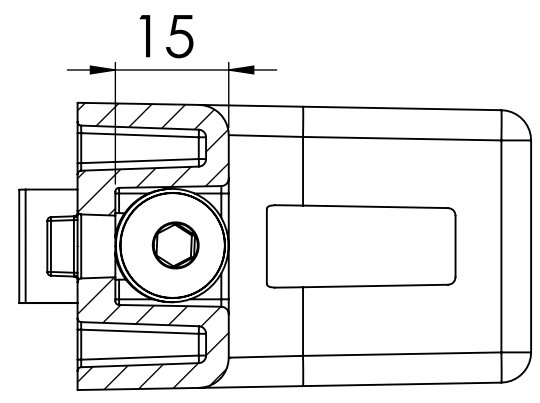
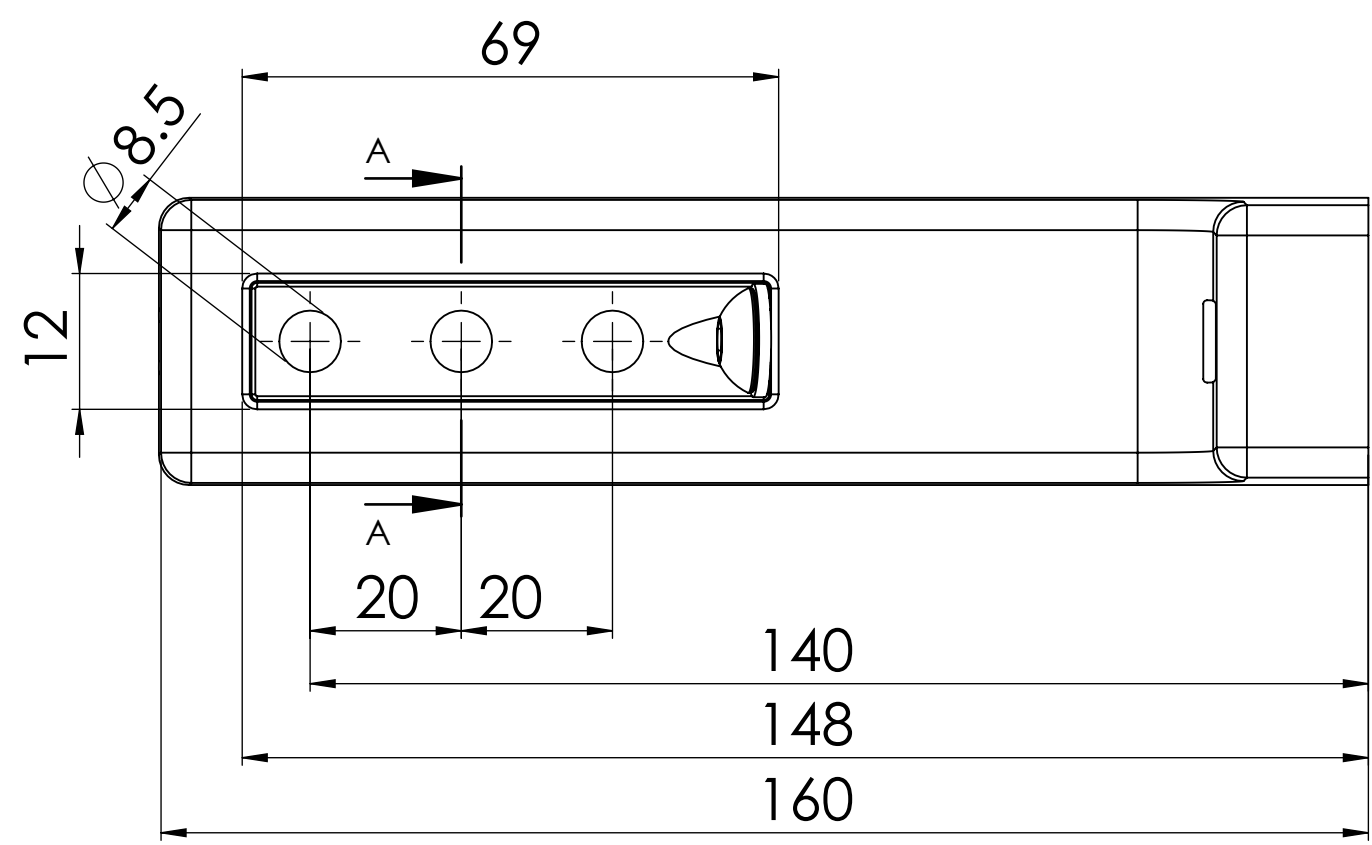
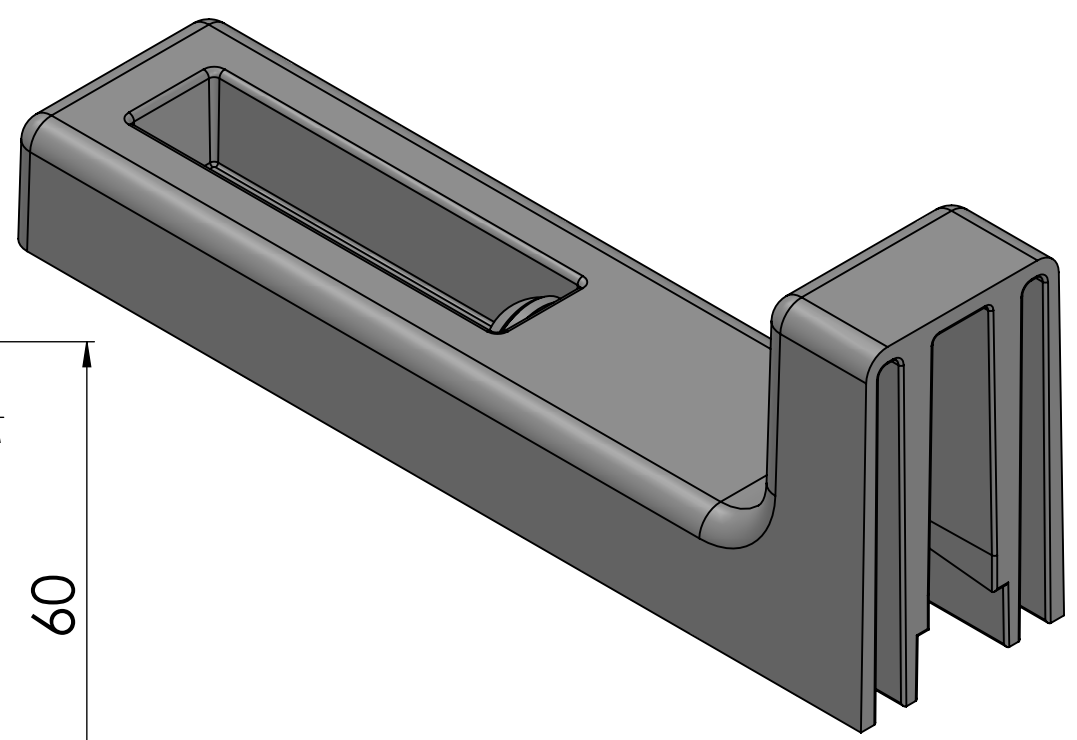
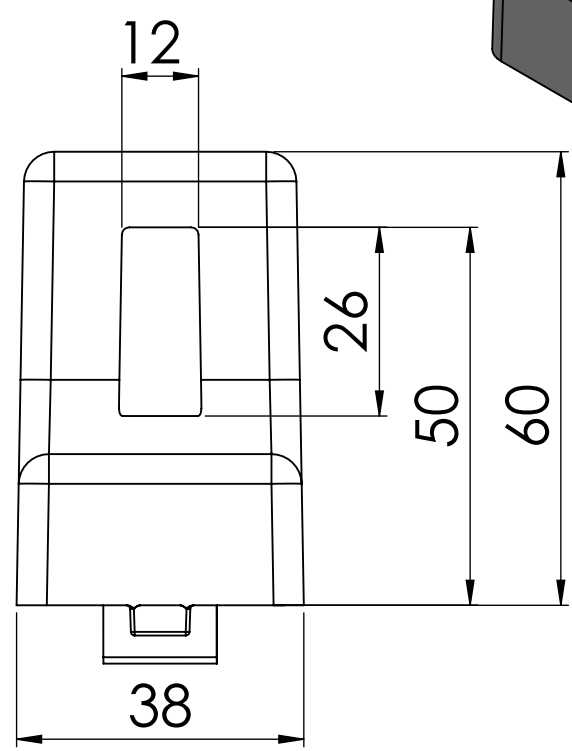
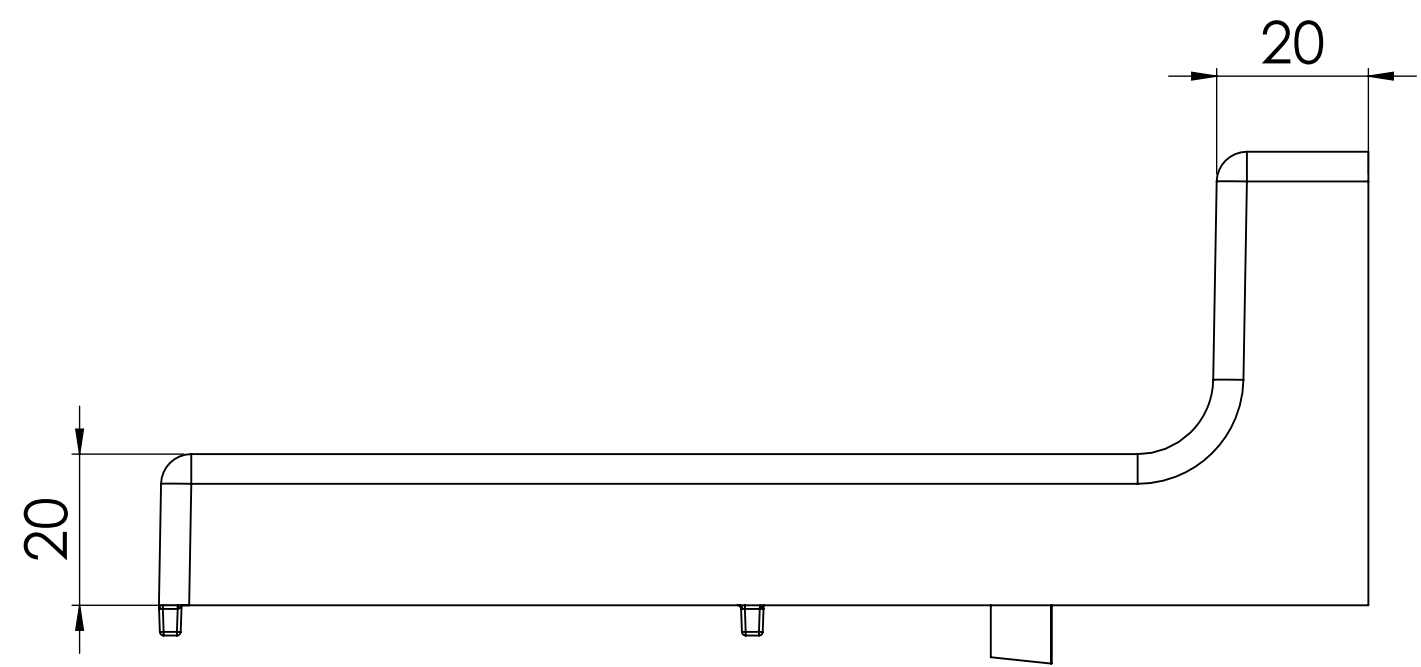

SECTION A-A

A

A

Note:-
*ALL UNMENTIONED FILLETS ARE 0.2MM

		UNLESS OTHERWISE SPECIFIED:		NAME	DATE			
		DIMENSIONS ARE IN MILLIMETERS		DRAWN		TITLE:		
		TOLERANCES:		CHECKED				
		FRACTIONAL ±		ENG APPR.				
		ANGULAR: MACH ± BEND ±		MFG APPR.				
		TWO PLACE DECIMAL ±		Q.A.		Projection:-		
		THREE PLACE DECIMAL ±		THIRD ANGLE PROJECTION		SIZE	DWG. NO.	REV
		INTERPRET GEOMETRIC TOLERANCING PER:ISO 2768 MEDIUM				B	282146104	
		MATERIAL				SCALE: 1:1		WEIGHT:
		FINISH				SHEET 1 OF 1		
NEXT ASSY	USED ON	DO NOT SCALE DRAWING		DEBURR AND BREAK SHARP EDGES				
APPLICATION								

4

3

2

1