

4

3

2

1

B

B

A

A

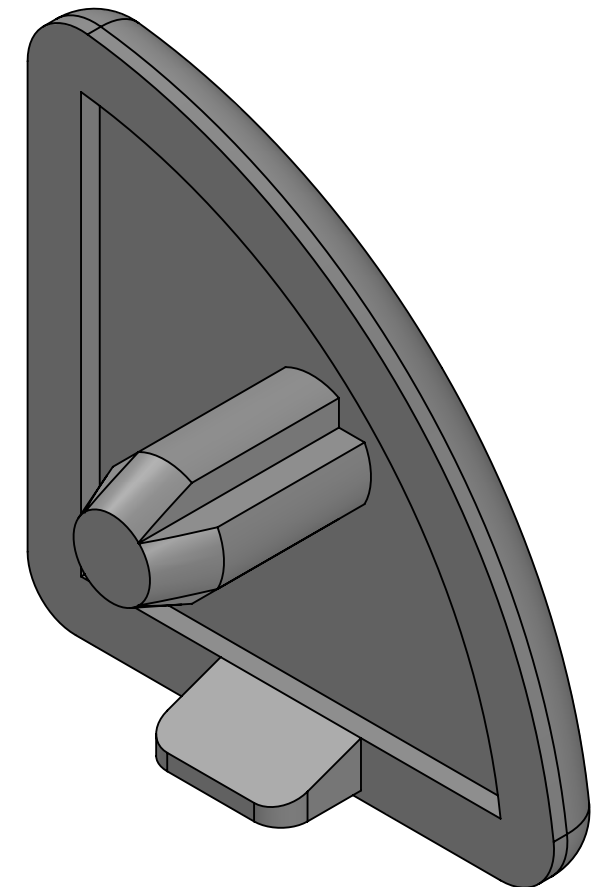
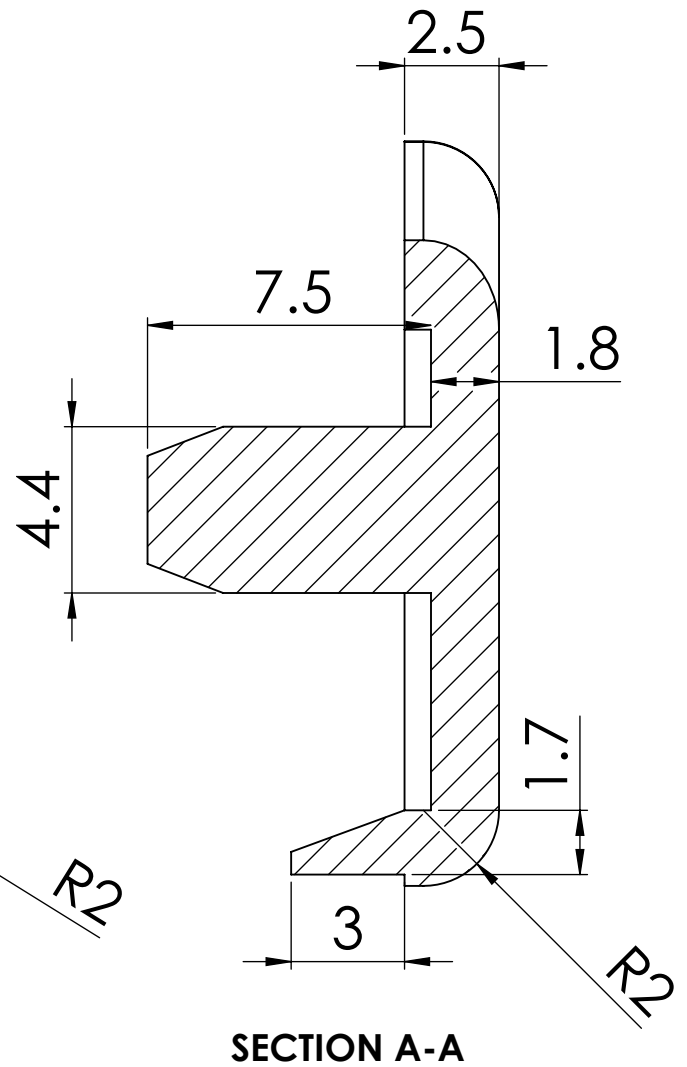
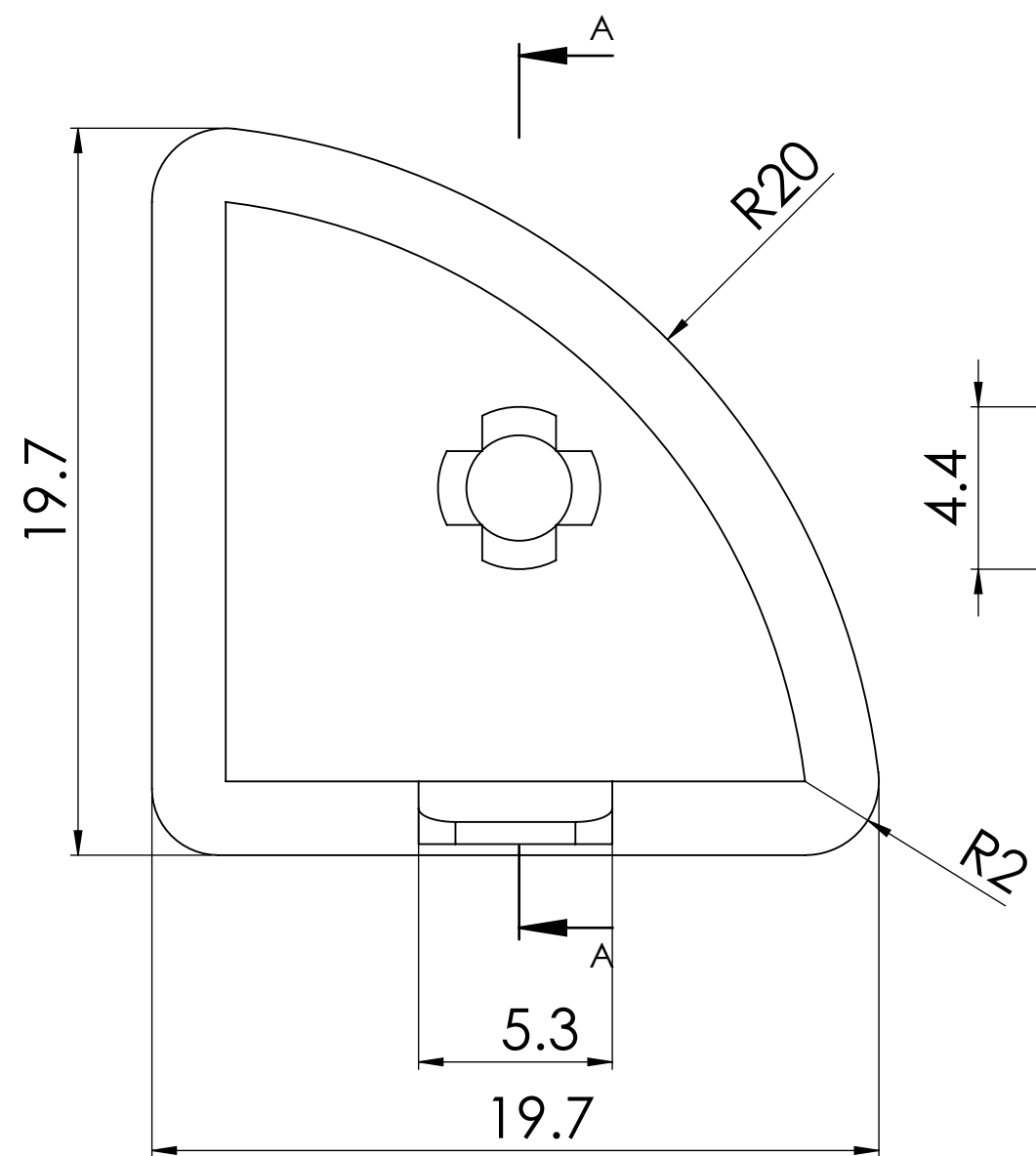

Note:-
*ALL UNMENTIONED FILLETS ARE 0.2MM

		UNLESS OTHERWISE SPECIFIED:		NAME	DATE		
		DIMENSIONS ARE IN MILLIMETERS		DRAWN		TITLE:	
		TOLERANCES:		CHECKED			
		FRACTIONAL ±		ENG APPR.			
		ANGULAR: MACH ± BEND ±		MFG APPR.			
		TWO PLACE DECIMAL ±		Q.A.			
		THREE PLACE DECIMAL ±		Projection:-		SIZE	DWG. NO.
		INTERPRET GEOMETRIC TOLERANCING PER:ISO 2768 MEDIUM		THIRD ANGLE PROJECTION		B	251005029
		MATERIAL				SCALE: 5:1	WEIGHT:
		FINISH				SHEET 1 OF 1	
NEXT ASSY	USED ON	DO NOT SCALE DRAWING		DEBURR AND BREAK SHARP EDGES			
APPLICATION							

4

3

2

1