

4

3

2

1

122

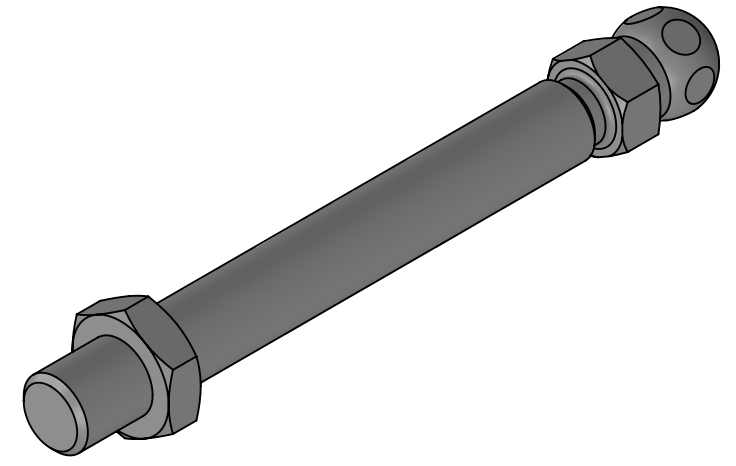
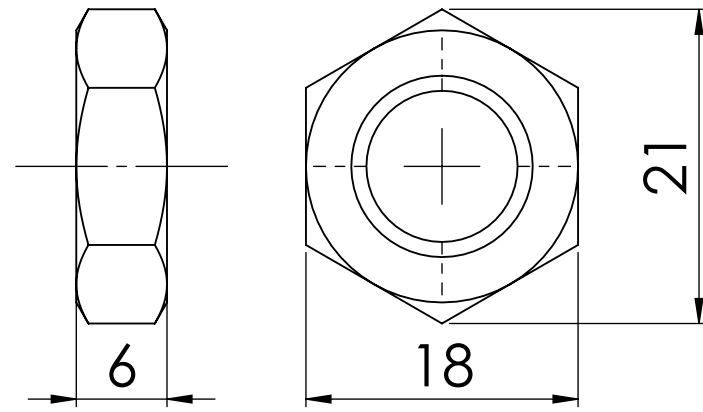
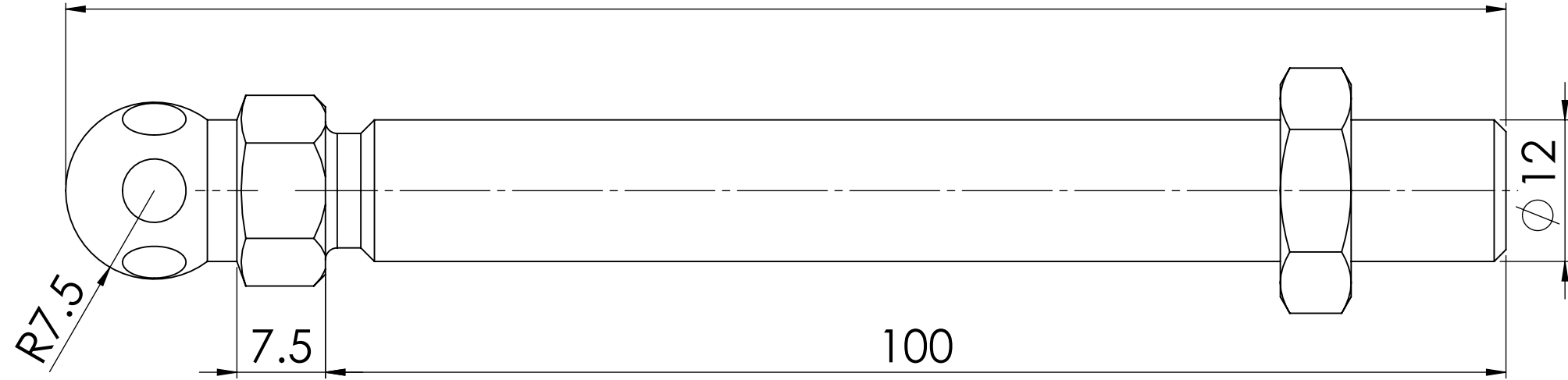
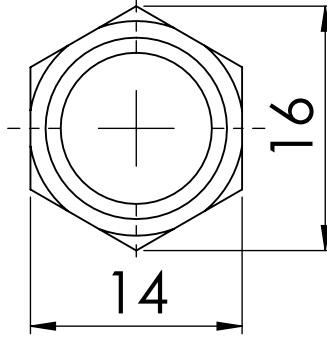

B

B

A

A

Note:-
*ALL UNMENTIONED FILLETS ARE 0.2MM

		UNLESS OTHERWISE SPECIFIED:	NAME	DATE		
		DIMENSIONS ARE IN MILLIMETERS	DRAWN			
		TOLERANCES:	CHECKED		TITLE:	
		FRACTIONAL: ±	ENG APPR.			
		ANGULAR: MACH ± BEND ±	MFG APPR.			
		TWO PLACE DECIMAL ±	Q.A.			
		THREE PLACE DECIMAL ±	Projection:-			
		INTERPRET GEOMETRIC TOLERANCING PER:ISO 2768 MEDIUM	THIRD ANGLE PROJECTION	SIZE	DWG. NO.	REV
		MATERIAL				
NEXT ASSY	USED ON	FINISH				
APPLICATION		DO NOT SCALE DRAWING	DEBURR AND BREAK SHARP EDGES	SCALE: 1:1	WEIGHT:	SHEET 1 OF 1
			SIZE B		DWG. NO. 203600360	

4

3

2

1