

8 7 6 5 4 3 2 1

D

D

C

C

B

B

A

A

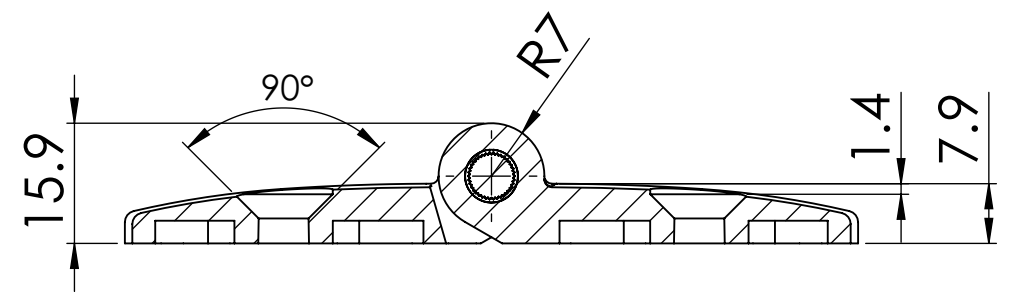
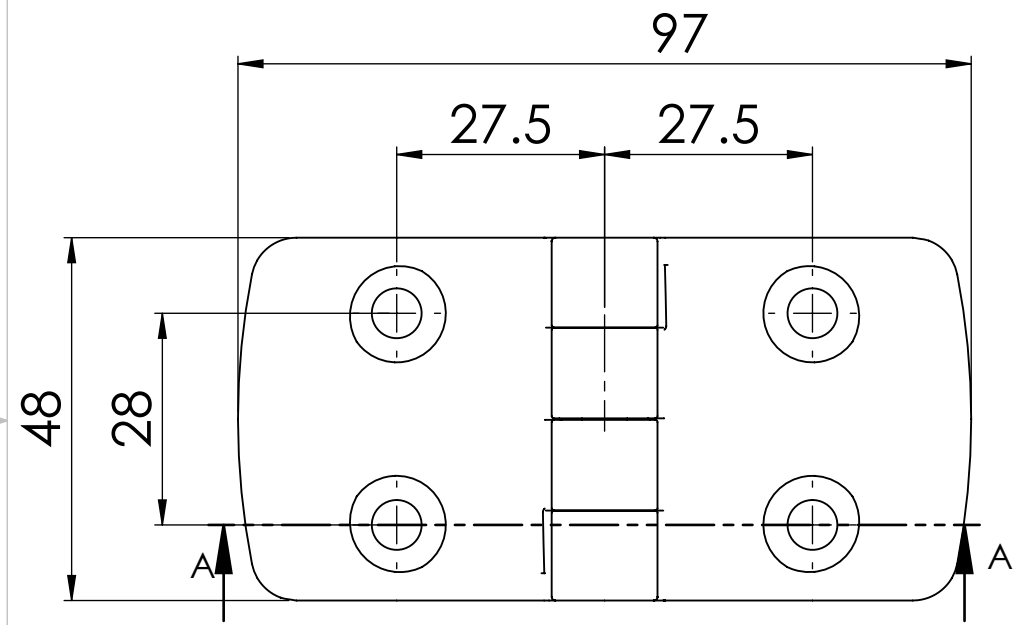
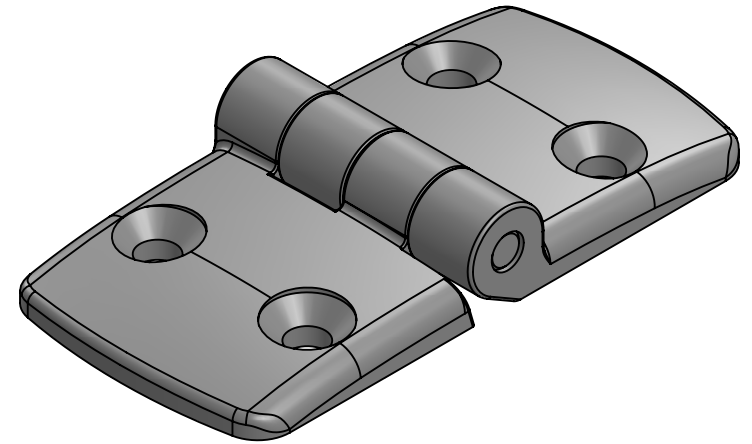

SECTION A-A

NOTE :-
ALL UNMENTIONED FILLETS ARE 0.2 MM

		UNLESS OTHERWISE SPECIFIED:		NAME	DATE
		DIMENSIONS ARE IN MILLIMETERS		DRAWN	
		TOLERANCES:		CHECKED	
		FRACTIONAL ±		ENG APPR.	
		ANGULAR: MACH ± BEND ±		MFG APPR.	
		TWO PLACE DECIMAL ±		Q.A.	
		THREE PLACE DECIMAL ±		PROJECTION:	
		INTERPRET GEOMETRIC TOLERANCING PER: ISO 2768 MEDIUM			
		MATERIAL		SIZE	DWG. NO.
		FINISH		B	202535646
NEXT ASSY	USED ON			REV	
APPLICATION		DO NOT SCALE DRAWING	DEBURR AND BREAK SHARP EDGES	SCALE: 1:1	WEIGHT:
				SHEET 1 OF 1	

8 7 6 5 4 3 2 1